

DELAVAN RLD FLAT SPRAY NOZZLE

Delavan RLD Flat Spray Nozzles for use on Hydraulic Continuous Casting Machines

Spray Characteristics

- Produces a uniformed flat spray without hard edges
- Thick flat spray pattern provides greater cooling efficiency than a standard flat spray nozzle
- Standard Spray Angle available - 80°
- Maximum recommended pressure - 35 bar

Construction and Materials

- Brass construction with stainless steel location pin and circlip
- Easy removal of internals for cleaning and maintenance
- Exit orifice inline with location pin

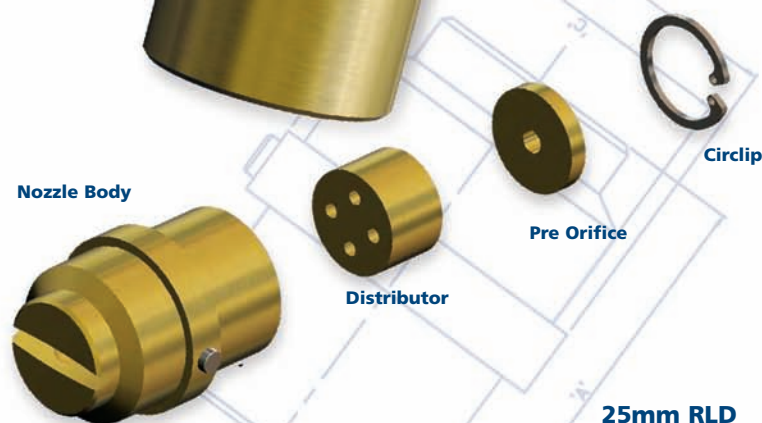

Body Size	Nozzle Size	Flow rates L/Min at BarG				
		1.4	2.8	4.1	5.5	6.9
25mm	4	2.8	4.0	4.8	5.6	6.3
	5	3.5	5.0	6.1	7.1	7.9
	6	4.2	6.0	7.3	8.4	9.4
	8	5.6	8.0	9.7	11.2	12.5
	10	7.1	10.0	12.1	14.0	15.7

Flow rates GPM at PsiG					
20	40	60	80	100	
0.7	1.1	1.3	1.5	1.7	
0.9	1.3	1.6	1.9	2.1	
1.1	1.6	1.9	2.2	2.5	
1.5	2.1	2.6	3.0	3.3	
1.9	2.6	3.2	3.7	4.1	

Body Size	Nozzle Size	Flow rates L/Min at BarG				
		1.4	2.8	4.1	5.5	6.9
38mm	4	2.8	4.0	4.8	5.6	6.3
	6	4.2	6.0	7.3	8.4	9.4
	7	4.9	7.0	8.5	9.8	10.9
	9	6.4	9.0	10.9	12.6	14.1
	10	7.1	10.0	12.1	14.0	15.7
	12	8.5	12.0	14.5	16.8	18.8
	13	9.2	13.0	15.7	18.2	20.4
	14	9.9	14.0	16.9	19.6	22.0
	15	10.6	15.0	18.2	21.0	23.5
	16	11.3	16.0	19.4	22.4	25.1
	18	12.7	18.0	21.8	25.2	28.3
	25	17.7	25.0	30.3	35.0	39.2
	30	21.2	30.0	36.3	42.0	47.1
	45	31.8	45.0	54.5	63.1	70.6

Flow rates GPM at PsiG					
20	40	60	80	100	
0.7	1.1	1.3	1.5	1.7	
1.1	1.6	1.9	2.2	2.5	
1.3	1.8	2.2	2.6	2.9	
1.7	2.4	2.9	3.3	3.7	
1.9	2.6	3.2	3.7	4.1	
2.2	3.2	3.8	4.4	5.0	
2.4	3.4	4.2	4.8	5.4	
2.6	3.7	4.5	5.2	5.8	
2.8	4.0	4.8	5.6	6.2	
3.0	4.2	5.1	5.9	6.6	
3.4	4.8	5.8	6.7	7.5	
4.7	6.6	8.0	9.3	10.4	
5.6	7.9	9.6	11.1	12.4	
8.4	11.9	14.4	16.7	18.7	

25mm RLD

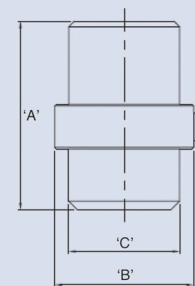

38mm RLD

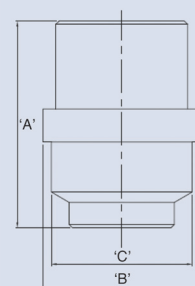

If you require a flow rate that is not stated
Please contact Delavan for further sizes

Nozzle Type	Dimensions in mm / in						Weight g/oz	
	A	B	C					
25mm RLD	34	1.3	25	1.0	20	0.8	130	4.6
38mm RLD	50	2.0	38	1.5	34	1.3	300	10.6

GOODRICH

DELAVAN
Spray Technologies

Delavan Ltd – Gorsey Lane – Widnes – Cheshire – WA8 0RJ – UK
Telephone: +44 (0) 151 424 6821 Fax: +44 (0) 151 495 1043
Inside USA Toll Free: (800) Delavan
e-mail: sales@delavan.co.uk or delavanspray@goodrich.com

Details of all our products are available on
our website @ www.delavan.com



ISO 9001:2000
FM 523589